

- **System Monitoring Solid State Relay**
- **LED Status Indicators**
- **Alarm Output Signal**
- **Zero Voltage Switching**

The SMR Series of System Monitoring Relays offer the user a number of fault condition alarms. Low line voltage, load circuit high impedance, damaged relay output and loss of DC supply

current constantly monitored by this unique Solid State Relay (SSR).

The alarm circuit output is a normally on NPN transistor capable of sinking current up to 100mA. State-of-the-art Surface Mount Technology assembly ensures reliability in a compact standard SSR package.

Manufactured in Crydom's ISO 9001 Certified facility for optimum product performance and reliability.

MODEL NUMBERS	SMR2425	SMR2450	SMR2490
<b>OUTPUT SPECIFICATIONS ①</b>			
Operating Voltage (47-63 Hz) [Vrms]	60-280	60-280	60-280
Max. Load Current ③ [Arms]	25	50	90
Min. Load Current, [mArms]	40	40	40
Transient Overvoltage [Vpk]	600	600	600
Max. Surge Current, (16.6ms) [Apk]	250	625	1200
Max. On-State Voltage Drop @ Rated Current [Vpk]	1.6	1.6	1.6
Thermal Resistance Junction to Case (R <sub>θJC</sub> ) [°C/W]	1.02	0.63	0.28
Maximum I <sup>2</sup> t for Fusing, (8.3 msec.) [A <sup>2</sup> sec]	260	1620	6000
Max. Off-State Leakage Current @ Rated Voltage [mArms]	10	10	10
Min. Off-State dv/dt @ Max. Rated Voltage [V/μsec] ②	500	500	500
Max. Turn-On Time	1/2 Cycle	1/2 Cycle	1/2 Cycle
Max. Turn-Off Time	1/2 Cycle	1/2 Cycle	1/2 Cycle
Power Factor (Min.) with Max. Load	0.5	0.5	0.5

## INPUT SPECIFICATIONS ①

Logic Supply Voltage Range (pin 3)	8-32 Vdc
Turn-On Control Voltage Range (pin 6)	8-32 Vdc
Min. Turn-Off Voltage (pin 6)	0.4 Vdc
DC Supply Current @ 12 Vdc	8 mA
DC Control Current @ 12 Vdc	6 mA
Maximum Alarm Output Current	100 mA
Alarm On Output Voltage (Open), (pin 7)	Supply Voltage
Maximum Alarm Off Output Voltage @ 100 mA (Active Low), (pin 7)	1.5 Vdc
Alarm Delay (Min.-Max.)	30-100 msec.

## GENERAL NOTES

© 2007 CRYDOM Inc., Specifications subject to change without notice.

① All parameters at 25° C unless otherwise specified.

② Off-State dv/dt test method per EIA/NARM standard RS-443, paragraph 13.11.1

③ Heat sinking required, for derating curves see page 2.

For recommended applications and more information contact:

**USA:** Sales Support (877) 502-5500 **Tech Support** (877) 702-7700 FAX (619) 710-8540

Crydom Inc., 2320 Paseo de las Americas, Ste. 201, San Diego, CA 92154

**Email:** sales@crydom.com **WEB SITE:** http://www.crydom.com

**UK:** +44 (0)1202 606030 • **FAX** +44 (0)1202 606035 Crydom SSR Ltd., Arena Business Centre,

Holyrood Close, Poole, Dorset BH17 7FJ, Email: intsales@crydom.com.

**GERMANY:** +49 (0)180 3000 506

### GENERAL SPECIFICATIONS

Dielectric Strength 50/60Hz Input/Output/Base	4000 Vrms
Insulation Resistance (Min.) @ 500 Vdc	10 <sup>9</sup> Ohm
Max. Capacitance Input/Output	8 pF
Ambient Operating Temperature Range	-40 to 80°C
Ambient Storage Temperature Range	-40 to 125°C

### MECHANICAL SPECIFICATIONS

Weight: (typical)	3.0 oz. (86.5g)
Encapsulation:	Thermally Conductive Epoxy
Output Terminals:	Screws and Saddle Clamps Furnished, Unmounted
Input Connector (locking):	Panduit No. MLSS100-5 or Equivalent
Mating Connector (supplied):	Panduit No. CT100F22-5 or Equivalent

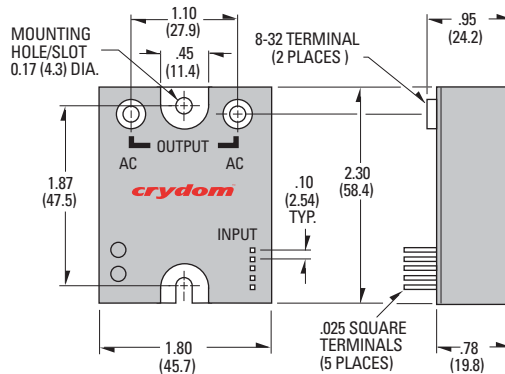

All dimensions are in inches (millimeters)  
**Screw Torque Requirements:**  
 8-32 Screws - 20in. lbs. (2.2 Nm)  
 (Screws dry without grease.)

### WIRING DIAGRAM

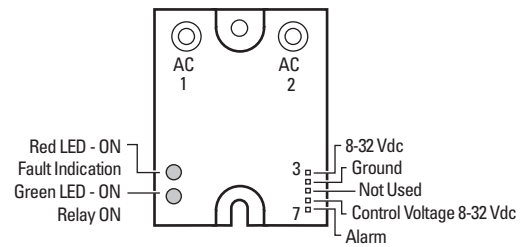

### CURRENT DERATING CURVES

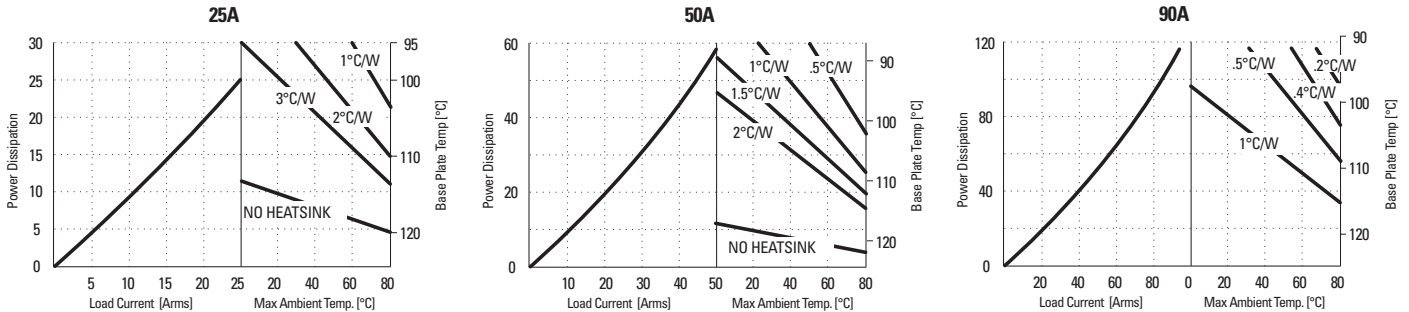

### STATUS CHART

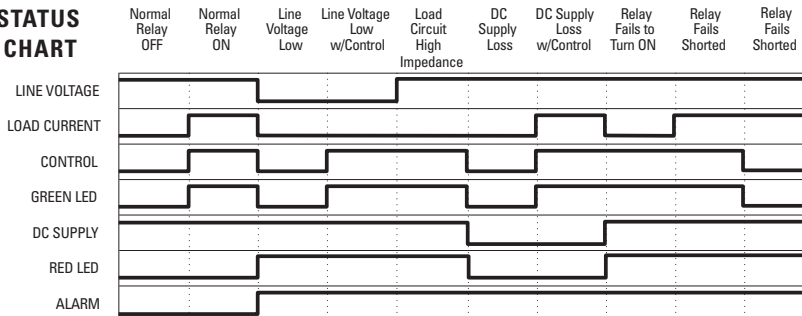

**Crydom Heat Sinks** offer excellent thermal management and are perfectly matched to the load current ratings of Crydom panel mount relays. Request Crydom's Heat Sink specification sheet for all the details.

### APPROVALS

UL E116949  
 CSA LR81689  
 VDE 10143 UG



© 2007 CRYDOM Inc., Specifications subject to change without notice.

For recommended applications and more information contact:  
**USA:** Sales Support (877) 502-5500 Tech Support (877) 702-7700 FAX (619) 710-8540  
 Crydom Inc., 2320 Paseo de las Americas, Ste. 201, San Diego, CA 92154  
**Email:** sales@crydom.com **WEB SITE:** http://www.crydom.com  
**UK:** +44 (0)1202 606030 • **FAX** +44 (0)1202 606035 Crydom SSR Ltd., Arena Business Centre, Holyrood Close, Poole, Dorset BH17 7FJ, Email: intsales@crydom.com.  
**GERMANY:** +49 (0)180 3000 506



**DANGER / PELIGRO / DANGER /GEFAHR / PERICOLO / PERIGO**

<p><b>HAZARD OF ELECTRIC SHOCK, EXPLOSION, OR ARC FLASH.</b></p> <ul style="list-style-type: none"> <li>• Disconnect all power before installing or working with this equipment.</li> <li>• Verify all connections and replace all covers before turning on power.</li> </ul> <p><b>Failure to follow these instructions will result in death or serious injury.</b></p>	<p><b>RIESGO DE DESCARGA ELECTRICA O EXPLOSION.</b></p> <ul style="list-style-type: none"> <li>• Desconectar todos los suministros de energia a este equipo antes de trabajar con este equipo.</li> <li>• Verificar todas las conexiones y colocar todas las tapas antes de energizar el equipo.</li> </ul> <p><b>El incumplimiento de estas instrucciones puede provocar la muerte o lesiones serias.</b></p>	<p><b>RISQUE DE DESCARGE ELECTRIQUE OU EXPLOSION</b></p> <ul style="list-style-type: none"> <li>• Eteindre toutes les sources d'énergie de cet appareil avant de travailler dessus de cet appareil</li> <li>• Vérifier tous connections, et remettre tous couverts en place avant de mettre sous</li> </ul> <p><b>De non-suivi de ces instructions provoquera la mort ou des lésions sérieuses.</b></p>	<p><b>GEFAHR EINES ELEKTRISCHE N SCHLAGES ODER EINER EXPLOSION.</b></p> <ul style="list-style-type: none"> <li>• Stellen Sie jeglichen Strom ab, der dieses Gerät versorgt, bevor Sie an dem Gerät Arbeiten durchführen</li> <li>• Vor dem Drehen auf Energie alle Anschlüsse überprüfen und alle Abdeckungen ersetzen.</li> </ul> <p><b>Unterlassung dieser Anweisungen können zum Tode oder zu schweren Verletzungen führen.</b></p>	<p><b>RISCHIO DI SCOSSA ELETTRICA O DELL'ESPLOSIONE.</b></p> <ul style="list-style-type: none"> <li>• Spenga tutta l'alimentazione e che fornisce questa apparecchiatura prima del lavorare a questa apparecchiatura</li> <li>• Verificare tutti i collegamenti e sostituire tutte le coperture prima della rotazione sull'alimentazione</li> </ul> <p><b>L'omissione di seguire queste istruzioni provocherà la morte o di lesioni serie</b></p>	<p><b>RISCO DE DESCARGA ELÉTRICA OU EXPLOÇÃO</b></p> <ul style="list-style-type: none"> <li>• Desconectar o equipamento de toda a energia antes de instalar ou trabalhar com este equipamento</li> <li>• Verificar todas as conexões e recolocar todas as tampas antes de religar o equipamento</li> </ul> <p><b>O não cumprimento destas instruções pode levar a morte ou lesões sérias.</b></p>
--	--	---	--	---	---

**WARNING / AVERTISSEMENT / WARNUNG / ADVERTENCIA / AVVERTENZA / AVISO**

<p><b>RISK OF MATERIAL DAMAGE AND HOT ENCLOSURE</b></p> <ul style="list-style-type: none"> <li>• The product's side panels may be hot, allow time for product to cool before touching.</li> <li>• Follow proper mounting instructions including torque values.</li> <li>• Do not allow liquids or foreign objects to enter this product.</li> </ul> <p><b>Failure to follow this instruction can result in serious injury, or equipment damage.</b></p>	<p><b>RISQUE DE DOMMAGE MATERIEL ET DE SURCHAUFFE DU BOITIER</b></p> <ul style="list-style-type: none"> <li>• Les panneaux latéraux du produit peuvent être chauds. Laisser le produit refroidir avant de le toucher.</li> <li>• Respecter les consignes de montage, et notamment les couples de serrage.</li> <li>• Ne pas laisser pénétrer de liquide ni de corps étrangers à l'intérieur du produit.</li> </ul> <p><b>Le non-respect de cette directive peut entraîner, des lésions corporelles graves ou des dommages matériels.</b></p>	<p><b>GEFAHR VON MATERIALSCHÄDEN UND GEHÄUSEERHITZUNG</b></p> <ul style="list-style-type: none"> <li>• Die Seitenwände können heiß sein. Lassen Sie das Produkt abkühlen, bevor Sie es berühren.</li> <li>• Beachten Sie die Montageanweisungen,</li> <li>• Führen Sie keine Flüssigkeiten oder Fremdkörper in das Produkt ein.</li> </ul> <p><b>Die Nichtbeachtung dieser Anweisung kann Körperverletzung oder Materialschäden zur Folge haben.</b></p>
<p><b>RIESGO DE DAÑOS MATERIALES Y DE SOBRECIENTAMIENTO DE LA UNIDAD</b></p> <ul style="list-style-type: none"> <li>• Los paneles laterales del producto pueden estar calientes. Esperar que el producto se enfríe antes de tocarlo.</li> <li>• Respetar las instrucciones de montaje, y en particular los pares de apretado.</li> <li>• No dejar que penetren líquidos o cuerpos extraños en el producto.</li> </ul> <p><b>Si no se respetan estas precauciones pueden producirse graves lesiones, daños materiales.</b></p>	<p><b>RISCHIO DI DANNI MATERIALI E D'INVOLUCRO CALDO</b></p> <ul style="list-style-type: none"> <li>• I pannelli laterali dell'apparecchio possono scottare; lasciar quindi raffreddare il prodotto prima di toccarlo.</li> <li>• Seguire le istruzioni di montaggio corrette.</li> <li>• Non far entrare liquidi o oggetti estranei in questo apparecchio.</li> </ul> <p><b>La mancata osservanza di questa precauzione può causare gravi rischi per l'incolumità personale o danni alle apparecchiature.</b></p>	<p><b>RISCO DE DANO MATERIAL E DE AQUECIMENTO</b></p> <ul style="list-style-type: none"> <li>• Os painéis laterais do produto podem estar quentes; dê tempo ao produto para arrefecer antes de lhe tocar.</li> <li>• Siga devidamente as instruções de montagem.</li> <li>• Não permita a entrada de líquidos e de objectos estranhos no produto.</li> </ul> <p><b>A não observância destas precauções pode provocar a morte, ferimentos graves ou danos materiais.</b></p>

## ANNEX – ENVIRONMENTAL INFORMATION:

The environmental information disclosed in this annex including the EIP Pollution logo are in compliance with People's Republic of China Electronic Industry Standard SJ/T11364 – 2006, Marking for Control of Pollution Caused by Electronic Information Products.

Part Name	Toxic or hazardous Substance and Elements					
	Lead (Pb)	Mercury (Hg)	Cadmium (Cd)	Hexavalent Chromium (Cr (VI))	Polybrominated biphenyls (PBB)	Polybrominated diphenyl ethers (PBDE)
Semiconductor die	X	O	O	O	O	O
Solder	X	O	O	O	O	O

### 附件 - 环保信息:

此附件所标示的包括电子信息产品污染图标的环保信息符合中华人民共和国电子行业标准 **SJ/T11364 - 2006**, 电子信息产品污染控制标识要求

部件名称	有毒有害物质或元素					
	铅 (Pb)	汞 (Hg)	镉 (Cd)	六价铬 (Cr (VI))	多溴联苯 (PBB)	多溴二苯醚 (PBDE)
半导体芯片	X	O	O	O	O	O
焊接点	X	O	O	O	O	O

